

**MasterMover®**

# MH400+ SS

Battery powered electric tug



†For illustrative purposes only, leg configuration may vary.

# MH400+ SS



## Overview

The Stainless Steel range of electric tugs delivers the same level of performance as our mild steel ranges, but with the added benefit of seamlessly integrating into sterile environments.

Whether it's a biopharmaceutical cleanroom suite or a food manufacturing facility, our stainless steel electric tugs remove manual handling and drive operational efficiency without compromising the cleanliness of your facility.

Constructed from high-grade 316 stainless steel and with IP ratings of up to IP55 available, stainless steel electric tugs are ideally suited to the stringent requirements of sterile environments.

The Stainless Steel range of electric tow tugs facilitate the controlled movement of loads in tight spaces, with an array of coupling options available that put load security and safety at the forefront.

## Key Features

### Safety

- Audible horn, flashing safety light, emergency stop button and anti-crush button
- Speed control with an optional two-speed selector switch for maximum control
- Complete load security with automatic braking

### Performance

- Powerful weight-moving capabilities suited to every application
- Maximum traction even on wet floors
- Compact and manoeuvrable to deliver precise movements in even the tightest of spaces

### Power

- Optimised motor output to optimise speed and power
- Maintenance-free, interchangeable battery options
- Powerful, effective, traction generation for smooth performance

### Connection

- Secure coupling systems to deliver the controlled movement of loads
- A range of coupling options available to connect to a variety of loads
- Custom couplings available



**MasterMover**





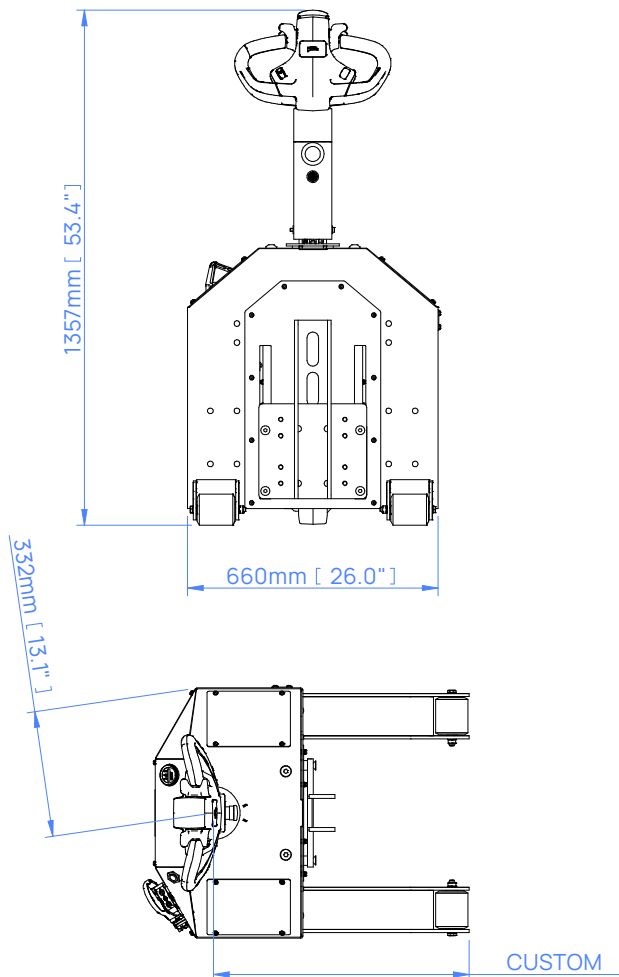
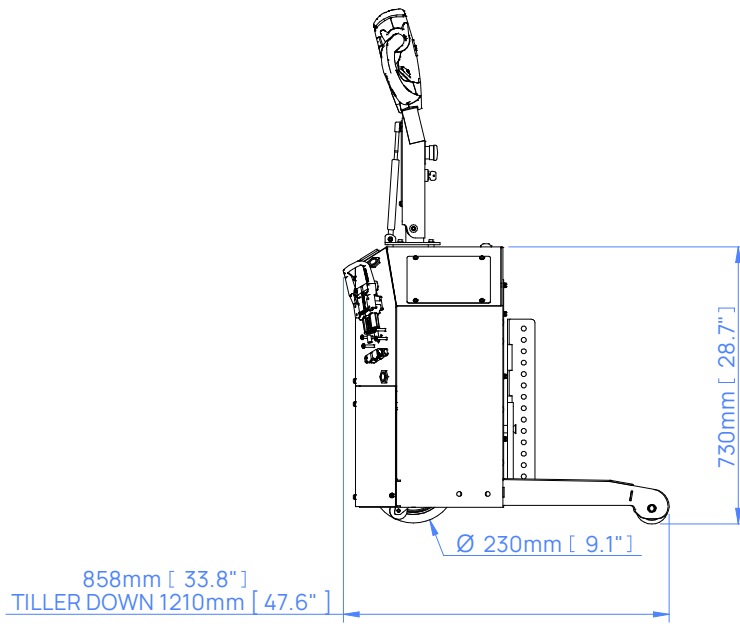

†For illustrative purposes only, leg configuration may vary.

# Dimensions



Support legs and couplings are customised for each customer application.

# Machine Safety Features

<p>Emergency Stop Button</p> 	<p>Anti-Crush Button</p> 	<p>Warning Horn</p> 
<p>Automatic Parking Brake</p> 	<p>Automatic Cut Off</p> 	<p>Battery Discharge Indicator</p> 
<p>Key Switch</p> 		

# Machine Options

<p>Two Speed Selector Switch Z76-00502</p> 	<p>Drive Wheel - 316 Stainless Steel Z76-00503</p> 
--	--

# Couplings

CombiCoupling  
Custom coupling

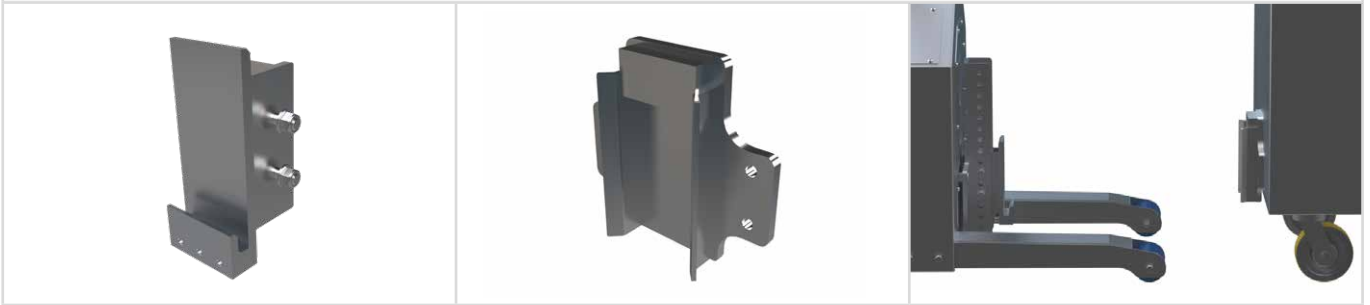

Channel Coupling  
Custom coupling



## Custom Engineering

We understand that every application is different. Whether it's a custom coupling to connect to your load, modifying our electric tugs to work in a challenging environment, or designing an entirely new solution for your application, our Customer Engineering team are here to help.

For more information on our custom engineering capabilities, please visit: [mastermover.com/custom-solutions](https://mastermover.com/custom-solutions)  
If you'd like to discuss your requirements, speak to your sales representative or email: [sales@mastermover.com](mailto:sales@mastermover.com)

# Technical Specification

Machine	
Product code	Z76-00100
Maximum load (on castors   on rails)	4,000 kg   16,000 kg
Maximum force (push   pull)	3,924 N   3,924 N
Machine weight	Custom
Battery weight (standard)	45 kg
Drive type	Electric
Braking	Regenerative
Parking brake	Electromagnetic
Drive wheel type	Non-marking Polyurethane
Castor wheel type	Non-marking Polyurethane
Drive wheel diameter	230 mm
Drive motor power	2 kW
Controller type	AC
Standard machine speed (Without two speed selector switch)	2 KPH
Hare mode speed (With two speed selector switch)	3 KPH
Tortoise mode speed (With two speed selector switch)	1.2 KPH
Maximum slope†	7°
Voltage	24 v
Noise level	Motor ≤80 dBA   Flashing light ≤85 dBA   Horn ≤112 dBA
Metal work finish	Stainless Steel 316 grade   180-grit abrasive to 0.76μ satin finish
IP rating	IP44
Battery	
Battery pack capacity	75 Ah
Maximum distance per charge*	9.2 km
Charge time	5 hrs 30 mins
External Charger	
Product code	Z76-00401
Input voltage	85 - 265 v
Hertz	50 - 60 Hz
Amps	15 A
Phase (single, three)	Single
IP Rating	IP30

# Technical Specification

Safety	
Key Switch	Standard
Emergency Stop Button	Standard
Battery Discharge Indicator	Standard
Anti-crush Button	Standard
Automatic Parking Brake	Standard
Warning Horn	Standard
Automatic Cut Off (as tiller arm returns to vertical)	Standard
Options	
Two Speed Selector Switch	Optional
Drive Wheel - 316 Stainless Steel	Optional

**MasterMover®**

mastermover.com

© Copyright 2024

UK  
CE ISO 9001 ISO 45001