

MasterHandler series

- ✔ Precise control of loads up to 13,200 lbs, with zero drift.

MasterHandler is our most compact, configurable electric tugger series for moving difficult-to-control loads up to 13,200 lbs. in space-constrained operations. A modular stabilizing leg slides under the load to eliminate drift and create a control point, for precise movement of loads with a full swivel or mixed-caster set-up.

Upgrade your MasterHandler to the Electric Steer model to unlock advanced control options. From remote control to innovative multi-machine synchronization as well as automation, for even more precision and visibility when moving long or heavy loads. With an adjustable leg system and interchangeable batteries, MasterHandler can be adapted to different loads and keeps working around the clock.



Benefits of the MasterHandler series

Improve safety

Eliminates manual handling and offers a safer alternative to traditional handling systems.

Compact power in tight spaces

High-power performance in a small machine footprint for precision maneuverability of awkward loads in confined, busy spaces.

Advanced control options

Upgrade to Electric Steer models for remote control, multi-machine synchronization and fully autonomous control options.

- ✔ Easily move up to 13,200 lbs.
- ✔ Ideal for full-swivel or mixed-caster setups
- ✔ Eliminate manual handling
- ✔ Adaptable for changing setups
- ✔ Easy-swap batteries for 24/7 operation
- ✔ No license needed
- ✔ Zero emissions
- ✔ Advanced technology options



Typical applications



Textiles & manufacturing

Move large A-frame trolleys, fabric stillages, and production equipment easily without the risk of drifting loads.



Pharmaceutical

Precisely maneuver large vessels, media totes, and chromatography columns through tight cleanroom environments.



Food & beverage

Handle heavy ingredient hoppers and processing equipment without castor drift to protect loads and people.

Key features

MultiLink & TillerLink upgrades

Combine the power of two machines with TillerLink or up to four machines with MultiLink for even more weight-moving capacity and precision control.

Stainless steel options

Safely move equipment in cleanroom environments with high-grade 316 stainless steel options.

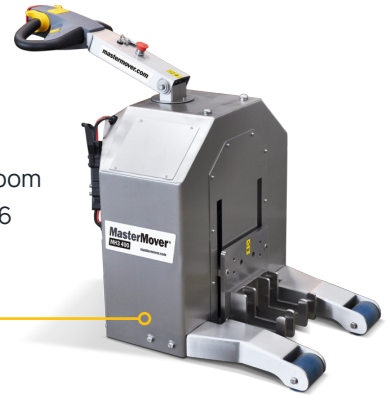

Hydraulic coupling systems

A range of coupling options are available to maximize performance, security and control.

Remote control option

Upgrade to Electric Steer models for remote control options, allowing operators to step away from the load during movement to maximize visibility.



Anti-drift stabilizing leg

A modular leg system, that adapts for changing setups, slides beneath the load to create a solid control point and prevent the load from drifting during movement.

Interchangeable battery system

Easy-swap batteries to maximize uptime across multi-shift environments.



Advanced technology options



Move even more & scale your operations



Remote control

Remote control operation gives operators the freedom to maneuver loads from the optimum position – improving visibility, reducing risk, and keeping control simple and intuitive.



TillerLink

TillerLink

Synchronize two pedestrian-operated MasterHandler tuggers to double the weight-moving power and maximize load stability. The machines work in unison to give one operator total control of challenging loads without compromising on precision or safety.



Multilink

MultiLink

Combine the power of multiple MasterHandler tuggers for even more weight-moving capacity with heavier loads, all operated from a single remote control. Using our innovative MultiLink technology, MasterHandler tuggers work together as one system so that the load is always protected.

Automation

Create repeatable, precise routes with line follow technology for efficient and accurate load movement that can be relied on day in, day out.

In application



MasterHandler models



MH400+

Moves up to Up to 8,000 lbs.



MH600+

Moves up to Up to 13,200 lbs.



Book a consultation today

See how the **MasterHandler series** can transform your load moving processes and boost operational efficiency.

sales.usa@mastermover.com
980-263-2210

